 **OUTDOOR USE ONLY!**  
**CAREFULLY READ THE SAFETY**  
**INSTRUCTIONS AND WARNING BEFORE USE**

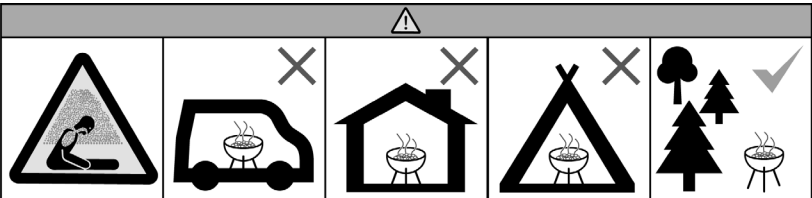



## SAFETY INFORMATION

### DANGER OF CARBON MONOXIDE POISONING!

#### WARNING!

**BURNING CHARCOAL INDOORS CAN BE FATAL. CARBON MONOXIDE IS RELEASED, AN ODOURLESS GAS. NEVER BURN CHARCOAL IN A ENCLOSED AREA, SUCH AS A DWELLING, CAR OR TENT.**

#### WARNING!

**FAILURE TO COMPLY WITH THE INSTRUCTIONS AND WARNINGS IN THIS MANUAL, CAN CAUSE FIRE, EXPLOSION, SERIOUS INJURY OR DEATH, INADDITION TO MATERIAL DAMAGE.**

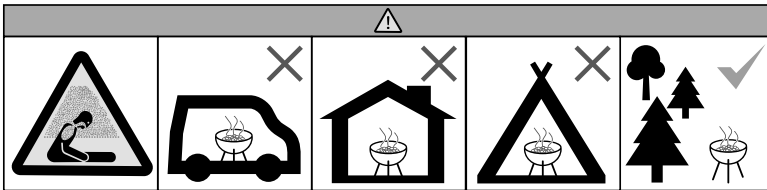

**WARNING!**  
**Do not use spirit or petrol for lighting or re-lighting!**

- For outdoor use only! Do not use under awnings, canopies, parasols or the like.
- Place grill on a firm, even and stable surface at a safe distance from buildings, trees and other flammable materials.
- The grill can be extremely hot when in use. Use grill gloves or other heat-resistant gloves when grilling to avoid burns.
- Only use grill implements made of heat-resistant materials.
- We recommend using grill lighter briquettes, a grill starter or electrical grill starter for the most effective, clean and safe way to start your grill. If using lighter fluid, do not ignite if there is any fluid on the outside of the grill, the area around it, on your own clothes etc.
- Do not use ethanol or petrol to light or relight charcoal or lighter briquettes. When using fluids to start a grill, ensure they approved according to EN 1860-3.
- Never relight the grill with any form of fluid, not even lighter fluid, as the charcoal can still be smouldering and cause large flames, a fire hazard and damage the grill.
- Always check that charcoal or briquettes are fully extinguished before removing ash.
- Never leave a grill in use or that has just been used without ensuring that all charcoal is fully extinguished.
- Let the grill cool down for at least 24 hours before emptying it, or empty used charcoal/briquettes into a metal container. Never empty used charcoal/briquettes directly onto the ground.
- Flames can shoot up if hot fat or food falls on to burning charcoal/briquettes. Always have water available to put out any such flames.
- Remember the danger of fire.
- Do not use the grill in strong winds.
- Always have a bucket of water to hand when grilling.
- Never leave a lit grill unsupervised.
- Wait until a white layer of ash covers the charcoal/briquettes before grilling.
- Do not empty used charcoal or briquettes back into the pack.
- Keep charcoal and briquettes dry and well ventilated and at a safe distance from heat sources.



**WARNING! KEEP CHILDREN, ANIMALS AND ANYONE ELSE WHO NEEDS SUPERVISION AT A SAFE DISTANCE FROM THE GRILL. THE GRILL CAN BE EXTREMELY HOT. NEVER MOVE THE GRILL ONCE LIT OR WHILE IT IS STILL HOT. DO NOT TOUCH THE GRILL BODY WHEN LIT, IT CAN BE EXTREMELY HOT AND THERE IS A RISK OF BURNS. DO NOT USE FLUIDS SUCH AS SPIRITS, PETROL, DIESEL, PARAFFIN OR ALCOHOL FOR LIGHTING OR RELIGHTING THE GRILL. WE RECOMMEND THE USE OF LIGHTING BRIQUETTES OR ELECTRICAL GRILL LIGHTERS.**

## AMOUNT OF CHARCOAL/BRIQUETTES

<b>Recommended amount of charcoal:</b>	<b>0,3 kilo</b>
<b>Maximum amount of charcoal:</b>	<b>0,5 kilo</b>
<b>Recommended amount of briquettes:</b>	<b>0,7 kilo</b>
<b>Maximum amount of briquettes:</b>	<b>0,9 kilo</b>



### WARNING!

Never overfill the grill with charcoal/briquettes, as it may damage the grill enamel if glowing charcoal falls from the charcoal grate and toward the grill body. Glowing charcoals may also fall out of the ventilation opening and cause fire or material damage when overfilled.

**DAMAGE CAUSED BY INCORRECT USE IS NOT COVERED BY THE WARRANTY.**

### GENERAL ASSEMBLY TIPS

#### Before assembling:

- Carefully read the assembly guide for the grill. Follow the instructions and safety instructions.
- Lay out all the parts and tools to make them easy to reach. Check all parts off against the list.
- Check that no parts are hidden in the packaging. Do not throw away the packaging before you have found all parts and the grill is fully assembled.
- Take your time!
- We recommend that two people assemble large grills to make it easier to keep parts in place during assembly.

#### During assembly:

Assemble all parts loosely first before tightening. Once all parts are assembled, tighten all screws.

#### Grills with hinged lids:

- Assemble the frame and wheels first.
- Attach the grill to the frame.
- Fit the side table, lid and hot shelf last.

# LIGHTING METHODS

WE RECOMMEND USING LIGHTING BRIQUETTES, CHARCOAL STARTER OR ELECTRIC GRILL STARTER FOR LIGHTING CHARCOAL/BRIQUETTES. LIGHTER FLUID IS NOT RECOMMENDED.

## During lighting

- Grills with lids: Always have the lid off or open during lighting. Never close the lid before the flames from the charcoal have died down - to avoid damaging the lid surface.
- NB: Only use the lid to suppress flames if the flames are getting out of control.
- Painted surfaces can be damaged by extreme heat.

## Lighting briquettes

- Place charcoal/briquettes in a pyramid.
- Place 3 - 6 lighting briquettes between the charcoal and carefully light them with a match.
- Once the charcoal/briquettes are burning and the flames/smoke have subsided, spread them over the charcoal grate. Never use your fingers, plastic implements or flammable objects to move burning charcoal. Use grill implements.
- Check that the grate is correctly positioned.
- Put on more charcoal when needed.

## Charcoal starter

- Insert the starter briquettes/tabs from the underside. Once there is a grey film on the charcoal/briquettes, they can be poured onto the charcoal grate.

## Electric grill lighters

- Lay a thick layer of charcoal or briquettes on the charcoal grate. Place the lighter on the charcoal/briquettes and make sure the handle is outside the grill.
- Place a new layer of charcoal or briquettes in a pyramid shape on the lighter.
- Plug in the lighter to the mains.
- The charcoal/briquettes will be alight after approx. 8 –15 minutes.
- Spread the charcoal/ briquettes in an even layer on the charcoal grate and you can start grilling.

## Lighter fluid

We do NOT recommend using lighter fluid for several reasons:

- It can cause large flames and increase the chance of burns.
- It collects in the bottom of the grill and can cause large flames after the grill has been alight for a while.
- Large amounts of fluid in the bottom of the grill can cause a lot of flames that can damage the grill surface.
- Fluid that leaks out of the grill can burn the exterior of the grill.
- Charcoal/briquettes soaked in fluid and lit before the fluid has soaked in
- Properly can cause large flames and burns. excessively large flames can also damage the grill surface.

## DURING GRILLING

- Read page 3 for correct amount of charcoal/briquettes.
- Do not overfill the grill with charcoal/briquettes. The grill can get too hot for cooking and the heat can represent a risk to people or animals in the vicinity.
- Using too much charcoal can also damage the grill surface and thus the paint enamel. .Paint and enamel are applied to protect the grill and damage can cause rust.
- The grill can be extremely hot when in use. Use grill gloves when grilling.
- If flames should appear during use - due to fat, marinade or the like dripping on to the charcoal - we recommend using a spray bottle to spray a little water on the charcoal.
- When finished using the grill, do not douse the charcoal with large amounts of COLD water, as this can damage the paint/enamel. Use sand or spray small amounts of water gradually and repeatedly.
- Always check that all embers are extinguished before removing used charcoal/briquettes. This can take up to 24 hours. Always dispose of ash and charcoal residue where they cannot cause fire.

## MAINTENANCE

- To make cleaning easy, cover the insides of the grill with aluminium foil before pouring charcoal in. The shiny side of the foil should be up. Remember to make holes in the foil for ventilation where necessary.
- Clean the grill grate with hot soapy water immediately after grilling. Dry the grate well and store in a dry place when not in use. We recommend coating the grate with food oil after cleaning, between each grilling and before storing.
- When storing the grill outdoors, keep it covered with a grill cover. Alternatively, the grill can be stored indoors, in a garage or under a roof.
- WARNING! Always check that all the charcoal is extinguished and that there are no embers left before putting a cover or on putting the grill away for storage.
- It is very important that the grill is totally dry before putting a cover on. Any dampness shut inside the grill cover can cause condensation and thus rust.
- It is important that grill and grates are cleaned after every use and before putting it into long-term storage. Residues of marinade, oils, fat etc. can cause mould and accelerate rust.
- We recommend repairing cracks or scratches in the paint or enamel with heat resistant paint as soon as possible. Stocked by ironmongers, builder's merchants, paint shops, workshops etc. Repair any rust as soon as possible before it spreads.

ASSEMBLY DRAWING

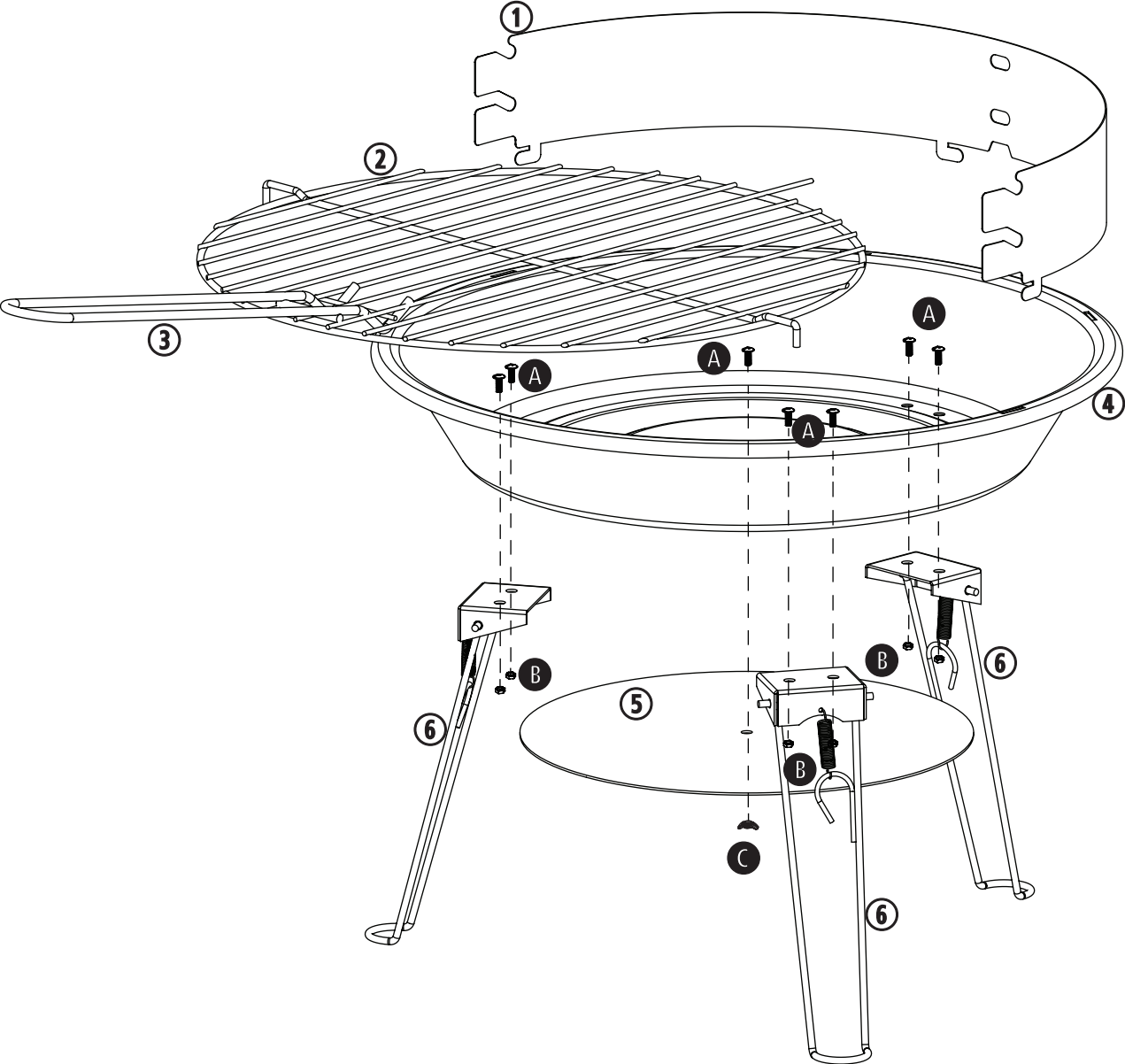

## PARTS LIST

<b>1</b>	Windshield	1
<b>2</b>	Cooking grill	1
<b>3</b>	Grill handle	1
<b>4</b>	Fuel bowl	1
<b>5</b>	Insulation board	1
<b>6</b>	Leg	3

<b>A</b>	Screw M5x10	7
<b>B</b>	Nut M5	6
<b>C</b>	Wing nut M5	1

# ASSEMBLY

## STEP 1

Attach legs (6) to fuel bowl (4) using screws (A) and nuts (B).

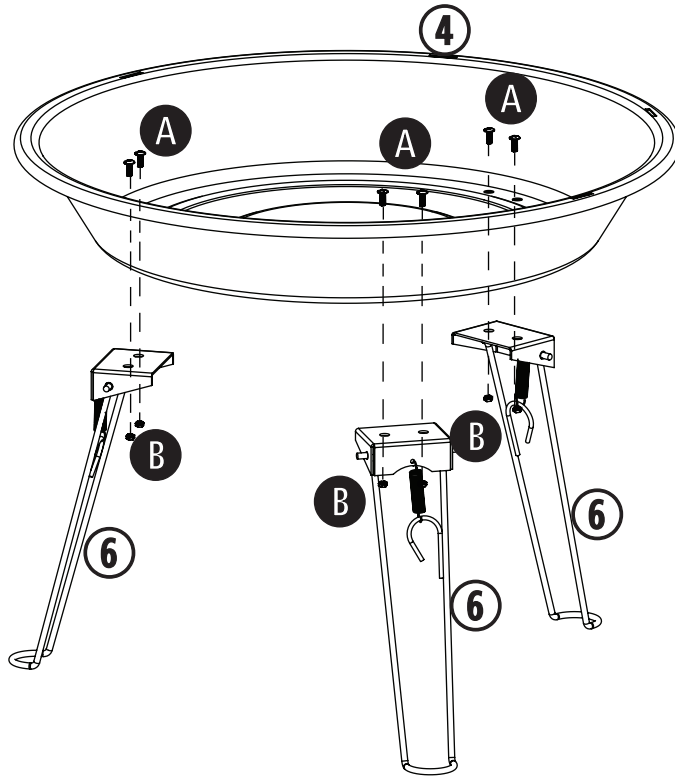

## STEP 2

Attach insulation board (5) to fuel bowl using screw (A) and wing nut (C).

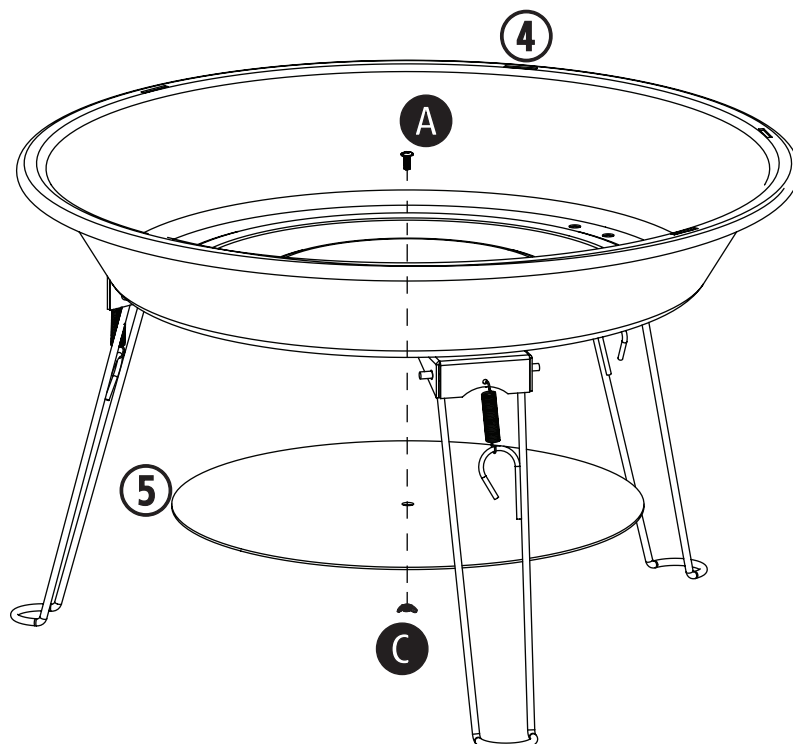



# ASSEMBLY

## STEP 3

Attach windshield (1) to fuel bowl (4).

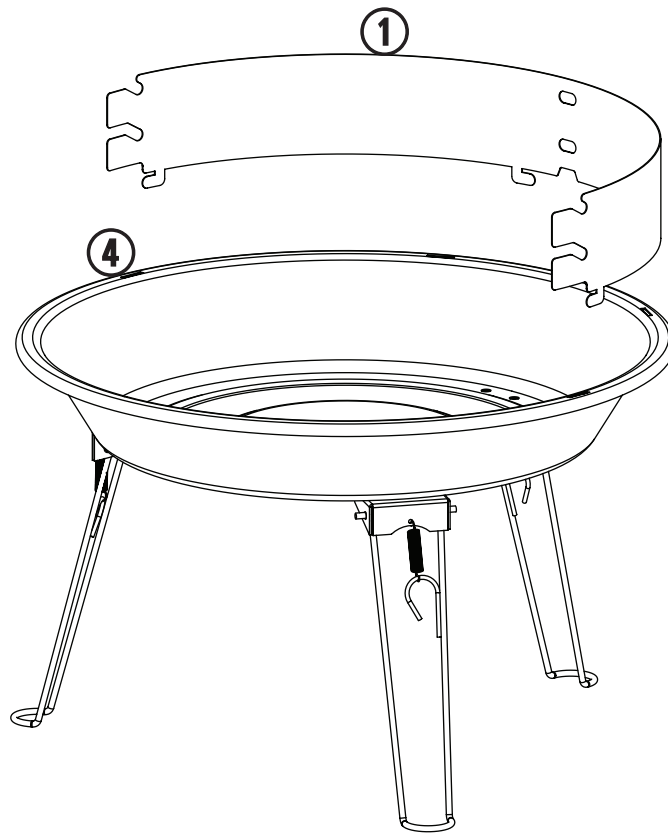

## STEP 4

Place cooking grill (2) into position.  
Attach grill handle (3) to cooking grill (2).

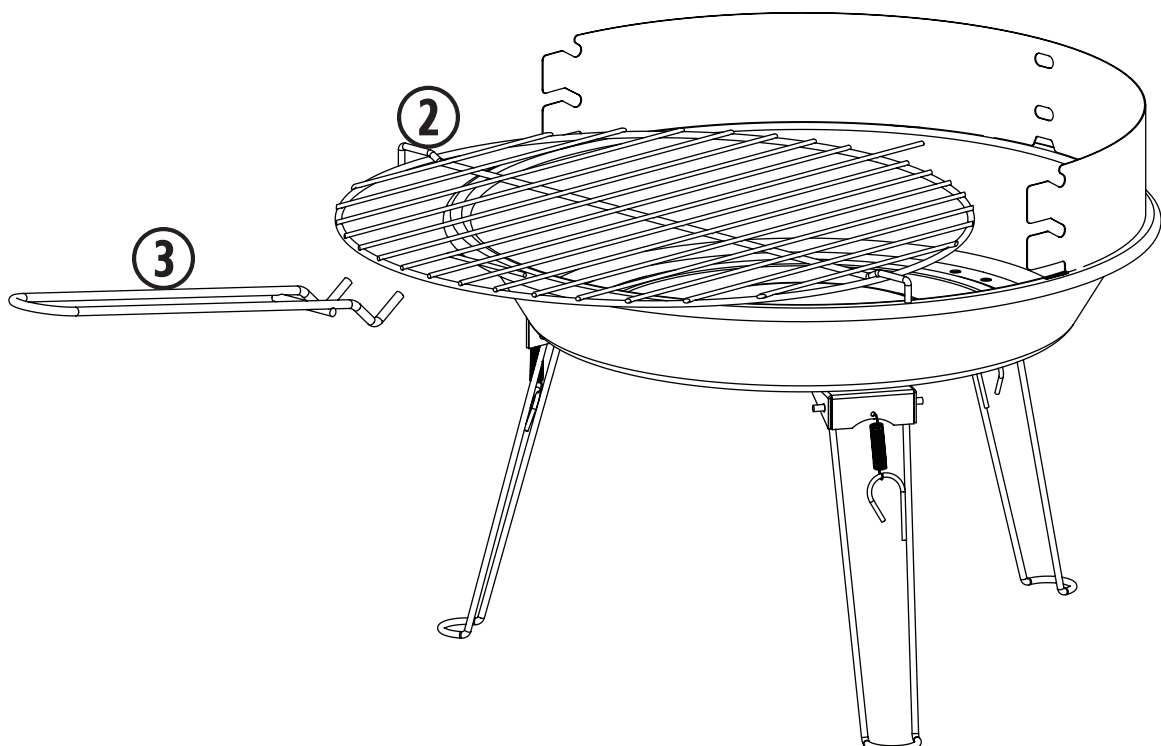

This product is covered by a warranty in accordance with consumer legislation. It has undergone strict quality controls and testing at the factory.

If there are any parts missing or the product has been damaged, please contact your dealer or the consumer contact below for help.

Faults due to misuse, lack of maintenance or modification of the product will invalidate the warranty.

Damaged parts not due to a fault with the product will be invoiced according to our price list + carriage and administration fee.

If new parts are needed or in the event of a warranty claim, please contact your dealer or consumer contact:

Consumer contact:

Nordic Season Products AS  
Kjeller Vest 3  
2007 Kjeller, Norge  
e-post: support@nordicseason.no  
tlf: 0047 924 78 600 (10-14 mon-fri)  
www.nordicseasonbbq.no

Always attach your receipt when making a warranty claim.  
Produced in China for Nordic Season Asia Co., Ltd.

**NORD C**  
**SEAS N**  
B A R B E C U E