



OUTDOOR USE ONLY!
CAREFULLY READ THE SAFETY
INSTRUCTIONS AND WARNING BEFORE USE

CONTENTS

Warnings	3
Technical data	4
Gas category	4
Assembly drawing	6
Parts list	7
Hardware	7
Assembly instructions	8-19
Gas leak test	20
Connecting gas	21
Lighting instructions	22-23
Before using the grill	24
Fat fire	25
Maintenance	26
Troubleshooting	27
Consumer Contact	28

WARNINGS



- Failure to follow the instructions provided can imply a risk of serious injury to personnel and fixed installations.
- Some grill parts can be sharp, we recommend wearing gloves when assembling and lifting. Sharp edges can cause injury.
- The grill is intended for outdoor use only in well-ventilated areas. Never grill in enclosed spaces or under a roof, due to the danger of the lack of oxygen.
- Accessible parts of the grill become very hot during use. Keep children and others who need supervision at a safe distance.
- Do not move the grill while in use or connected to the gas bottle. Shut off the gas on the regulator after use and disconnect from the gas bottle.
- Modification of the grill can cause danger and will invalidate the warranty.
- Never keep the gas bottle under the grill when in use. Gas leaks can cause serious damage. Place the gas bottle by the side of the grill during use.
- Do not place the grill cover or other flammable material in the compartment under the grill when it is in use or hot.
- Do not use lava stones, charcoal, lighting fluid or briquettes.
- Never light the grill with the lid closed, the vents in the grill must never be sealed or blocked.
- Clean the grill regularly and thoroughly
- Perform the leak test regularly and always when changing the gas bottle after long storage. Always check the gas hose for damage and cracks each time you use the grill.
- If storing the grill in a garage or basement below ground level, do not store the gas bottle the same place, as it must be stored above normal ground level.

TECHNICAL DATA

Total effekt: 14kW

Total gas consumption: 1019 g/h.

Hose and regulator (not included):

Must be approved according to EN standard.

Gas bottle (not included): Use standard bottle approved for use in the Nordic Region, 10/11 kg recommended. Even though butane and propane gas can be used, we recommend propane for use in the Nordic Region. Approved hoses and regulators are available from most outlets selling gas equipment.

NB!

GAS HOSES USED FOR THIS PRODUCT MUST NOT EXCEED 120 CM IN LENGTH.

GAS INFORMATION

FOR USE IN COUNTRIES	VALVE SIZE	GAS TYPE	GAS CATEGORY
BE, CH, CY, CZ, ES, FR, GB, GR, IE, IT, LT, LU LV, PT, SK, SI	0.91 mm	Butan (28~30) mbar Propan 37 mbar	I3+(28-30/37)
BE, CY, CZ, DK, EE, FI, FR, HU, IT, LT, NL, NO, SE, SI, SK, RO, HR, TR, BG, IS, LU, MT	0.91 mm	G30 (butan),G31 (propan) and mixture of these, LPG 28~30 mbar	I3B/P(30)
PL	0.87 mm	G30 (butan), G31 (propan) and mixture of these, LPG 37mbar	I3B/P(37)
AT, CH, DE, SK	0.80 mm	G30 (butan),G31 (propan) and mixture of these, LPG 50mbar	I3B/P(50)
 2531-23			
This product is produced according to EUROPEAN GAS APPLIANCE REGULATION (EU) 2016/426			

TECHNICAL DATA

143,5 cm







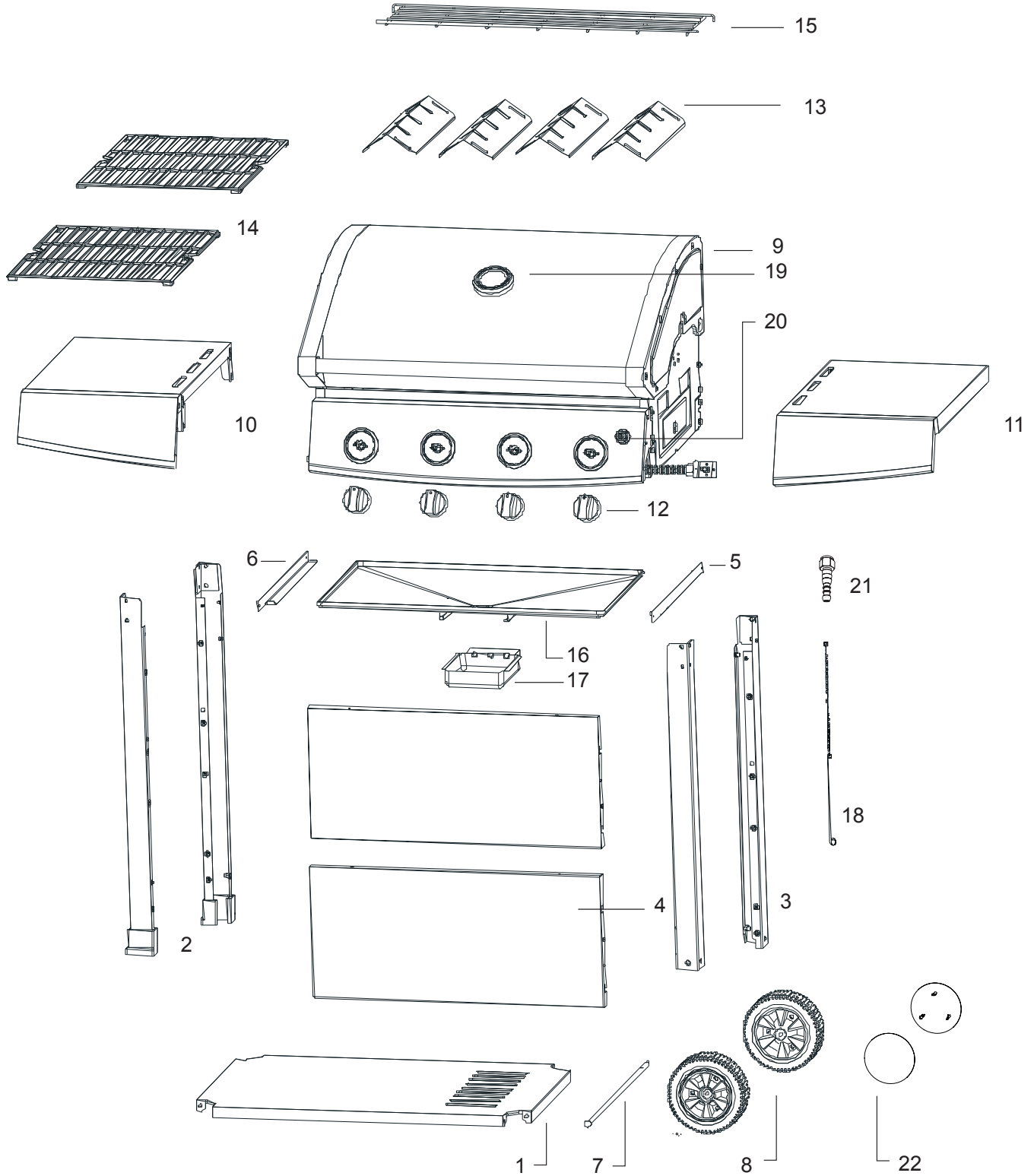

116 cm

ASSEMBLY DRAWING

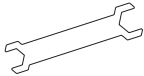

PARTS LIST

1	Bottom panel	1
2	Left leg assembly	2
3	Right leg assembly	2
4	Front panel	2
5	Right bracket for drip tray	1
6	Left bracket for drip tray	1
7	Wheel axle	1
8	Wheel	2
9	Firebox and hood	1
10	Left side table	1
11	Right side table	1
12	Knob	4
13	Flame tamer	4
14	Cooking grate	2
15	Warming rack	1
16	Drip tray	1
17	Grease cup	1
18	Matchstick holder assy	1
19	Thermometer	1
20	Igniter button	1
21	Connector assembly	1
22	Wheel cover	2

A		M6 nut	x1
A		Small spanner	x1
A		Axle washer	x1
B		M6x12 screw	x16
B		M6 lock washer	x16
C		M4x8 screw	x4
D		M6x16 screw	x9
D		M6 lock washer	x9

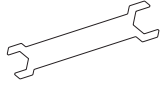
TOOLS FOR ASSEMBLY	
	
Philips/cross-point screwdriver (not included)	Small spanner (included)
WARNING! Screws and enamel can be damaged during assembly if power tools are used. Its not recommended to use power tools during assembly.	

ASSEMBLY



**PLEASE FOLLOW THESE INSTRUCTIONS STEP BY STEP.
WE RECOMMEND TWO PEOPLE TO ASSEMBLE THE GRILL TO
AVOID HEAVY LIFTING.**

Step 1:

Attach the four legs to bottom panel

Using M6x12 screws and M6 lock washers, secure left leg assembly (part 2) to bottom panel (part 1), and right leg assembly (part 3) with corresponding screws. Assemble 2 additional legs in same manner (see illustration).

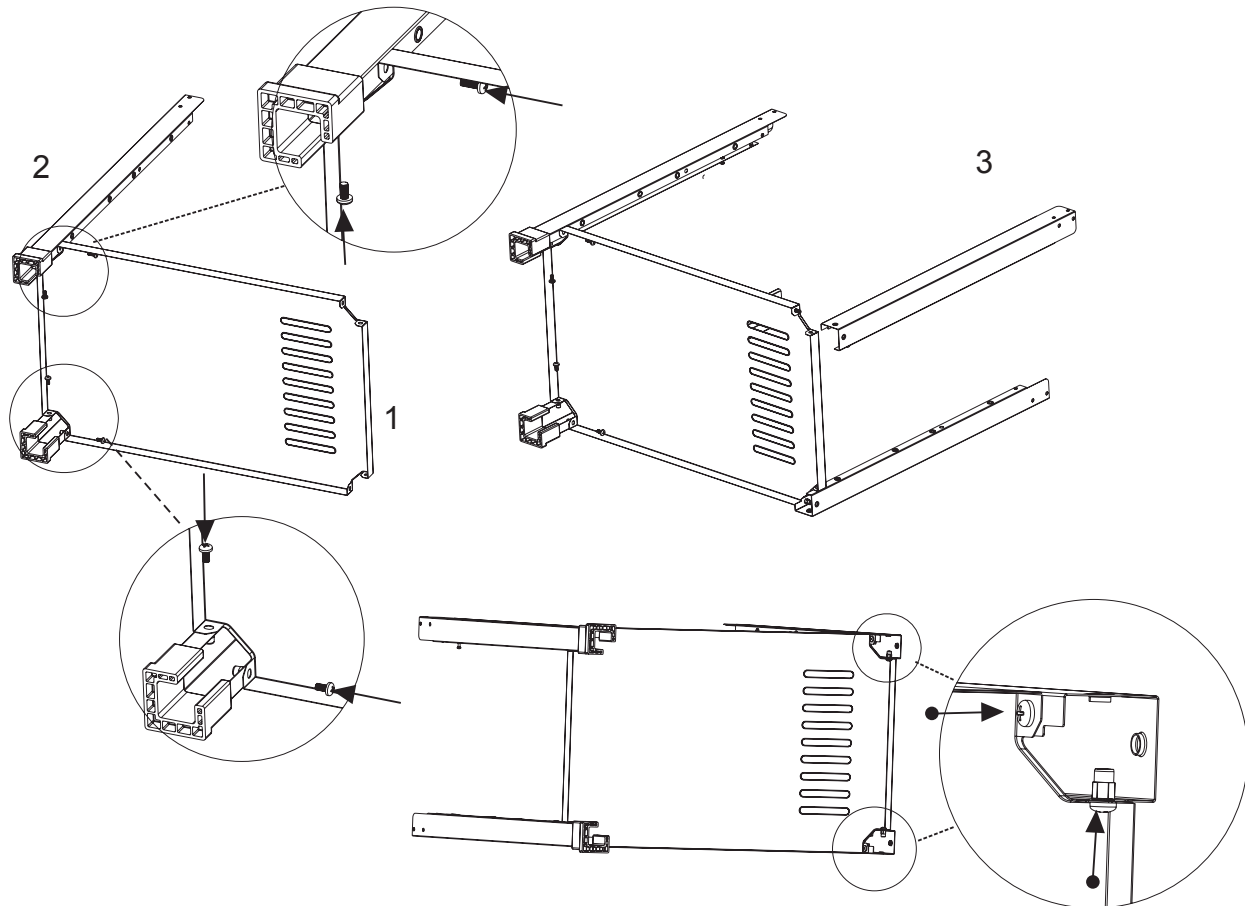

B. M6x12



8 PCS

B. M6x8



8 PCS

ASSEMBLY

Step 2:

Install the front panel

Insert the corresponding M6x12 screws with M6 lock washers into the pre drilled holes of the left and right legs located at the front of the cart. Do not tighten screws. Line up the slots in the front panel (part 4) to the screws. Slide the front panel into place.

Tighten the screws.

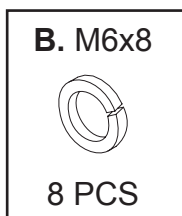
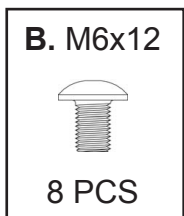
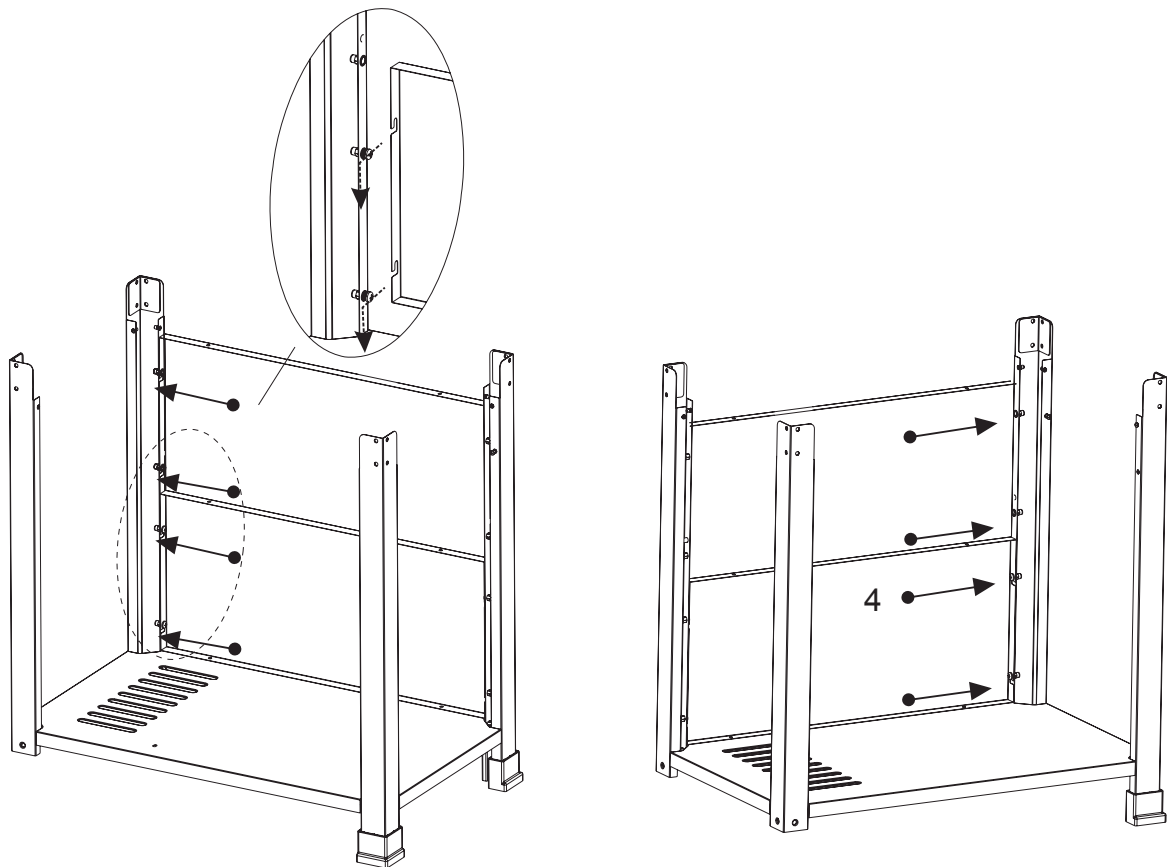

ASSEMBLY

Step 3:

Install the wheels

Insert the axle (part 7) into the wheel (part 8). Insert the axle into the pre drilled hole located on the right front leg of the cart (see illustration). The axle will then insert into coordinating hole in the cart leg at the back of the cart. Insert the additional wheel on the axle on the back side of the cart. Insert the axle washer on the axle and secure with the M6 lock nut. Tighten with the included spanner.

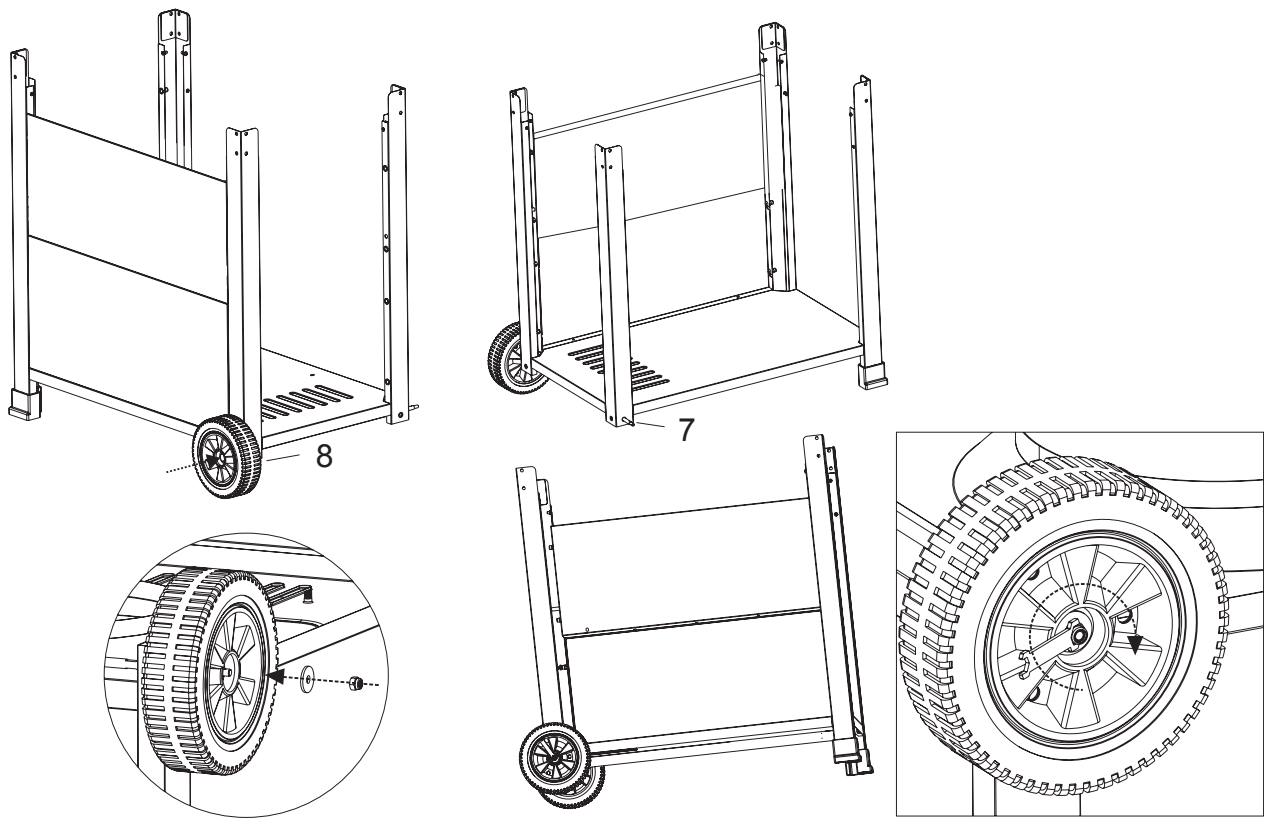

A. M6



1 PCS

A. Skive

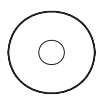

1 PCS

ASSEMBLY

Step 4:

Attach the wheel covers (22)

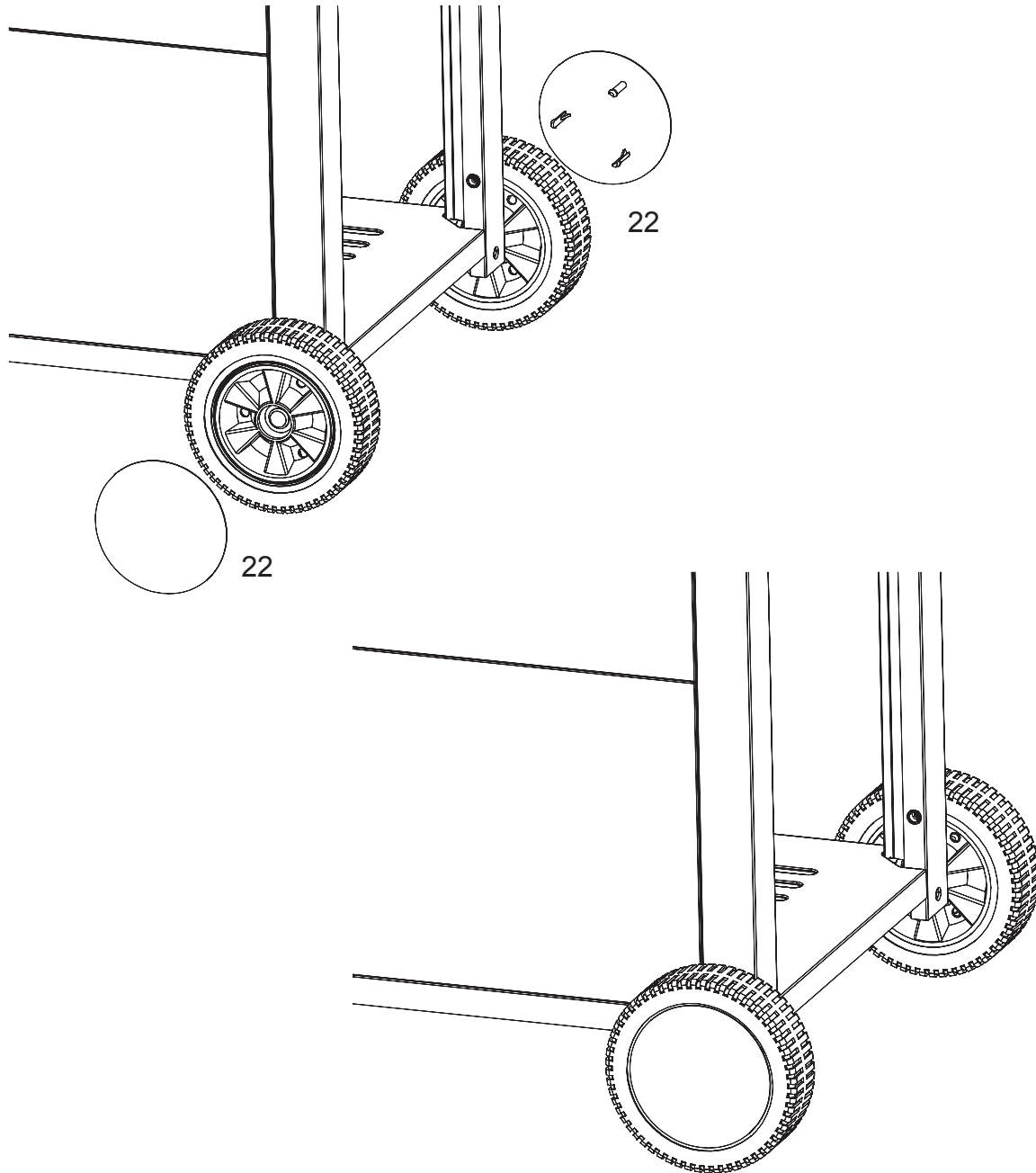

ASSEMBLY

Step 5:

Install left and right drip tray brackets

Lock the left bracket for drip tray (part 6) and right bracket for drip tray (part 5) into the mounting hole at left and right leg assembly with corresponding M4x8 screws.

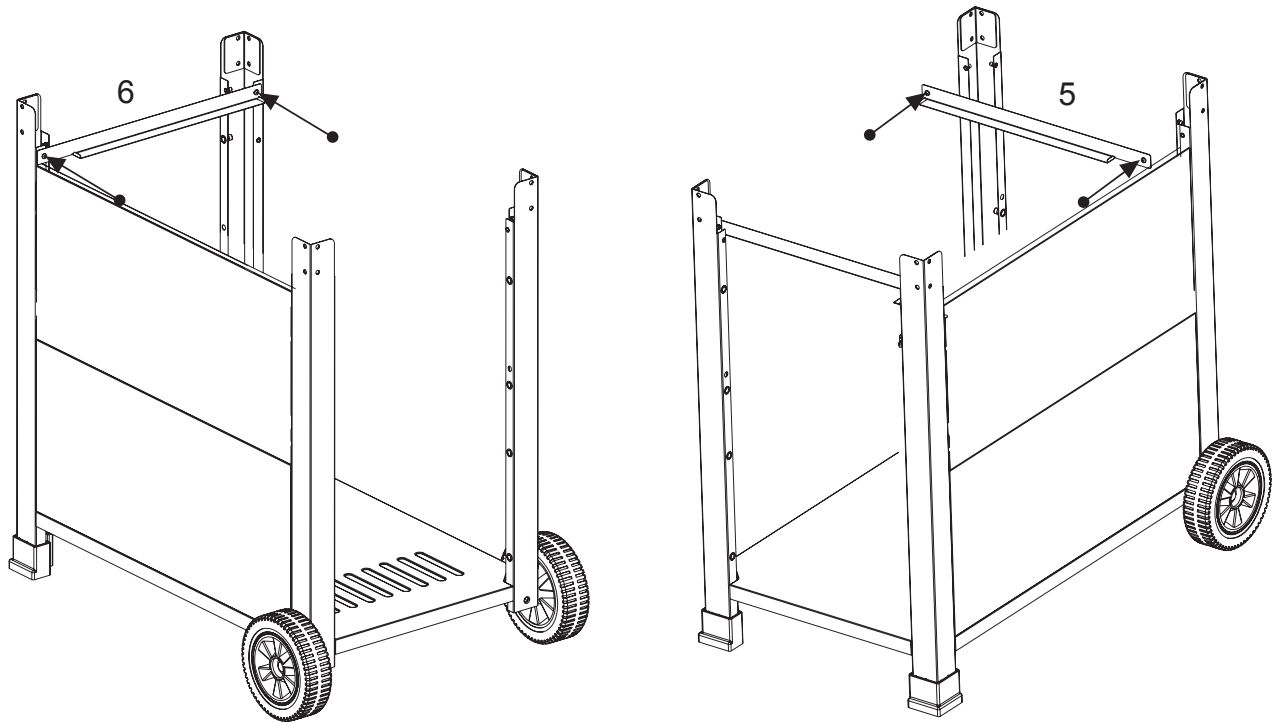

C. M4x8



4 PCS

ASSEMBLY

Step 6:

Install the firebox and hood assembly
Place the knob (part 13) on the valve stem (see illustration).
Set the firebox and hood assembly (part 9) on top of the cart panel. Secure the firebox and hood assembly with M6x16 screws and M6 washers at the top of each leg of the cart (see illustration).
Enter all the screws to the BBQ before tightening.
ATTENTION: Do not tighten the screws too hard as the enamel may crack.

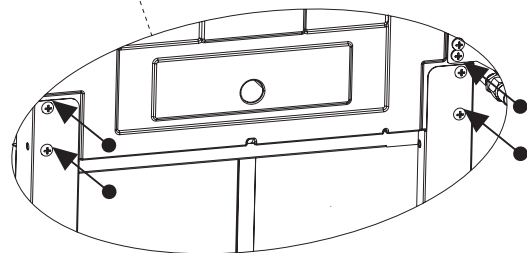
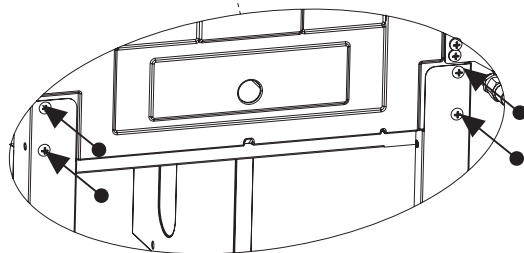
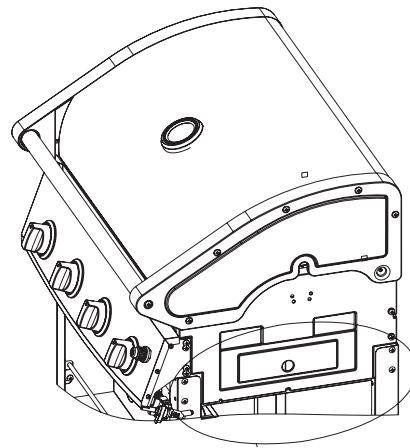
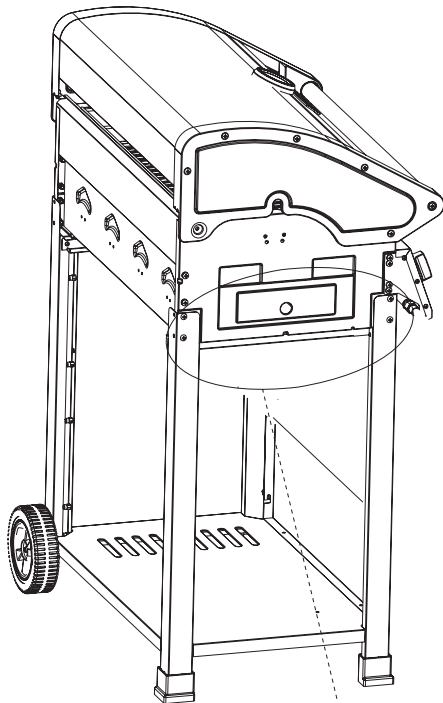
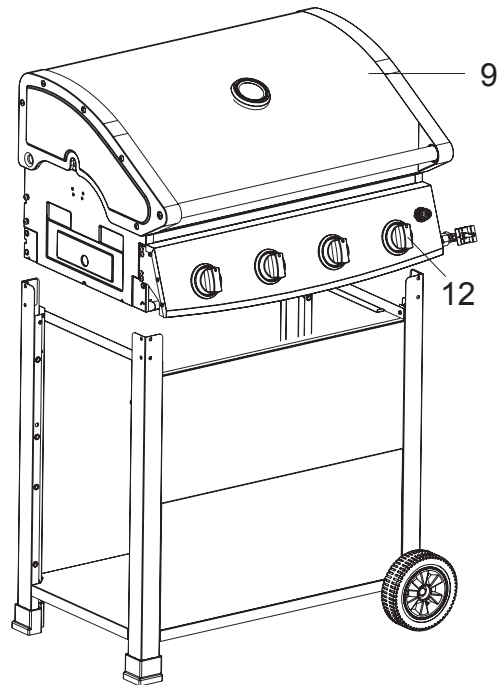
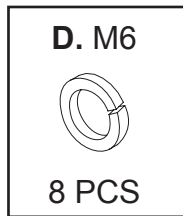
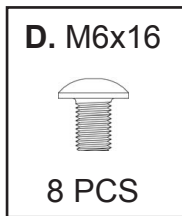

ASSEMBLY

Step 7:

Install the left side table
Line up the holes in the left side table (part 10) with the pre-installed screws on left side of firebox and hood assembly.
Slide left side table into place over the screws.
Tighten the pre-installed screws to secure the side table.

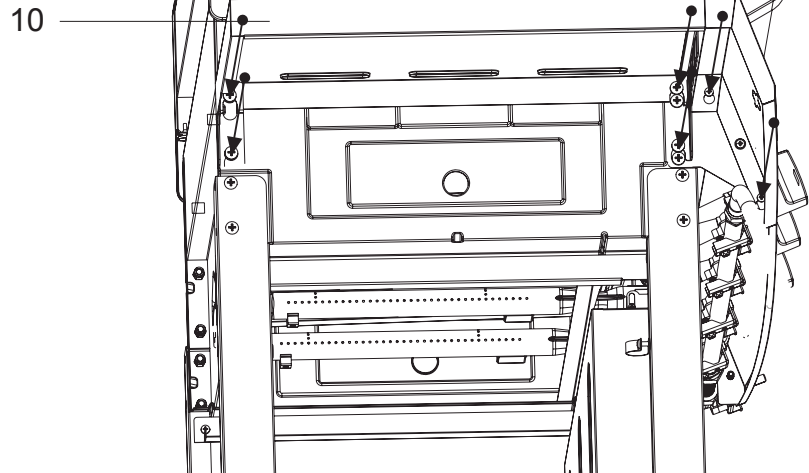

Step 8:

Install the right side table
Line up the holes in the right side table (part 10) with the pre-installed screws on right side of firebox and hood assembly.
Slide right side table into place over the screws.
Tighten the pre-installed screws to secure the side table.

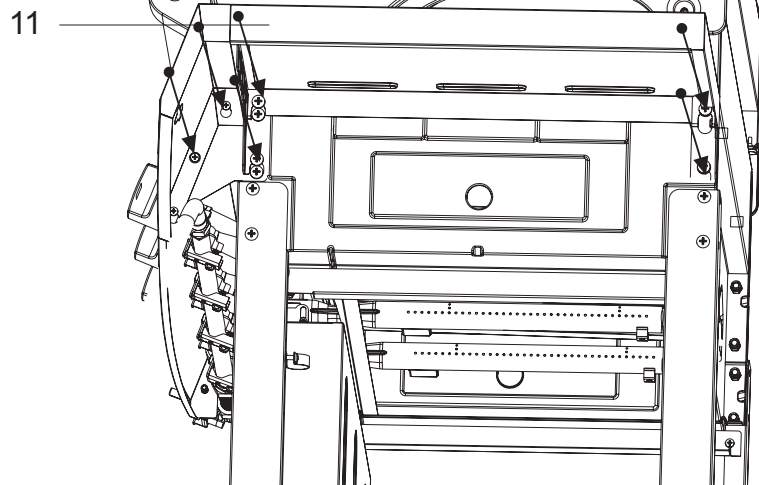

ASSEMBLY

Step 9:

Place the 4 flame tamers (part 13) over each burner inside the firebox. Vented end of flame tamers is placed toward the back of the firebox (see illustration).

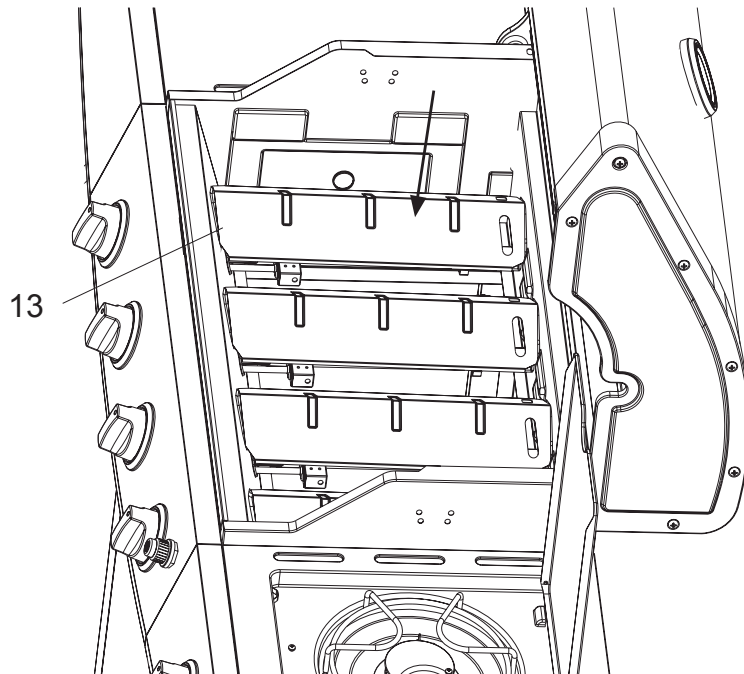

Step 10:

Place the cast iron cooking grate (part 14) into the firebox.

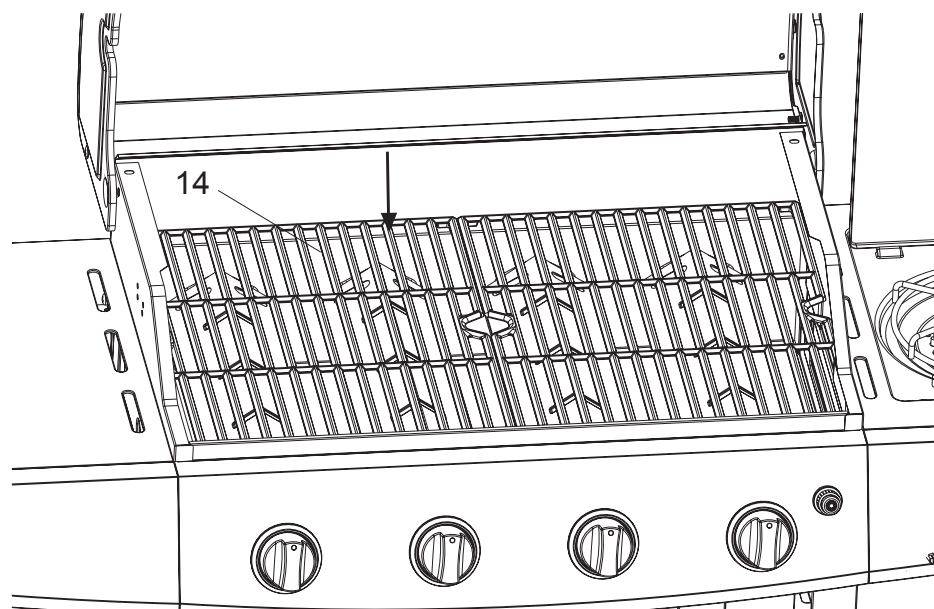

ASSEMBLY

Step 11:

Insert warming rack (part 15) , make sure that the tabs on the warming rack fit into the pre- drilled holes in the firebox (see illustration).

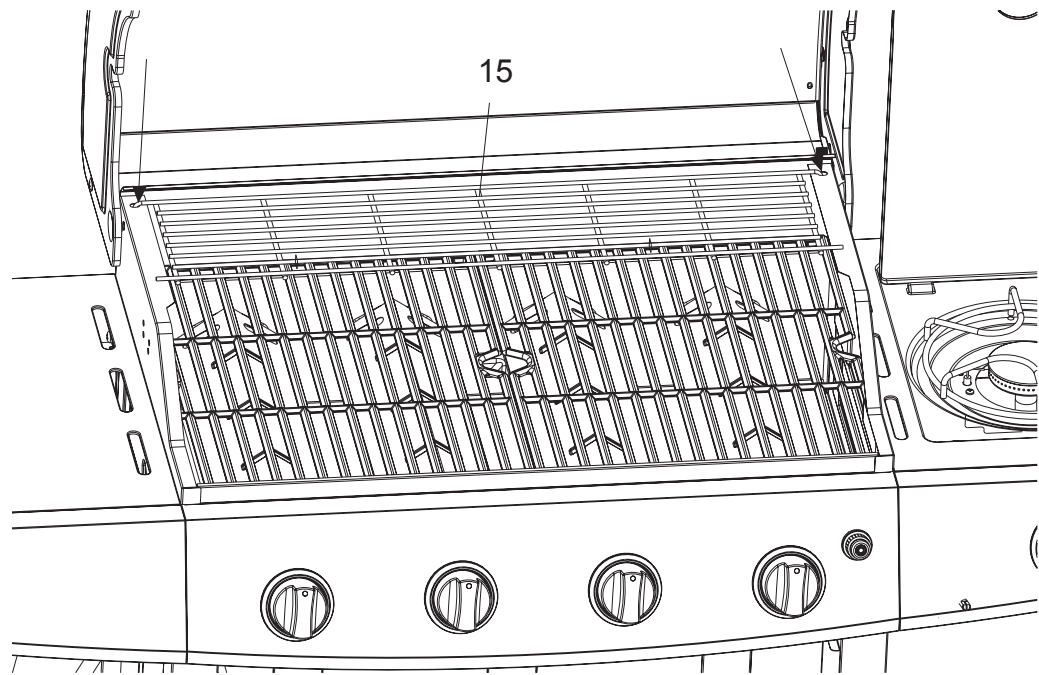

Step 12:

Insert the drip tray (part 16) into the drip tray brackets from the back of the grill. Insert the grease cup (part 17) into the brackets on drip tray (see illustration).

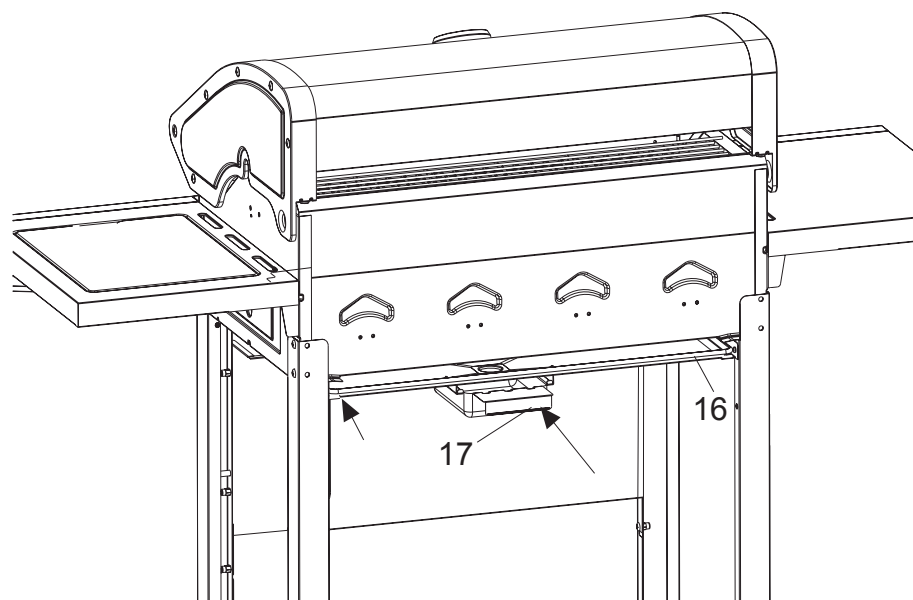

ASSEMBLY

Step 13:

Install M6X16 screw and M6 lock washer at the 2/3 position of back left leg of cart. Do not tighten screw. Hang the single loop end of matchstick holder (part 18) onto the screw. You may also hang the top loop on the other end of the matchstick holder over the same screw (see illustration below). This is a safety feature for use when lighting with a standard match. Please use with caution.

Locate ignitor button on front panel of grill. Unscrew the ignitor button. Place AA battery inside the ignitor negative end first. Make sure the spring is located inside the rubber boot of the ignitor button. Screw ignitor button back into place (see illustration).

Note: AA battery is not provided by manufacturer.

D. M6x16



1 STK

D. M6



1 STK

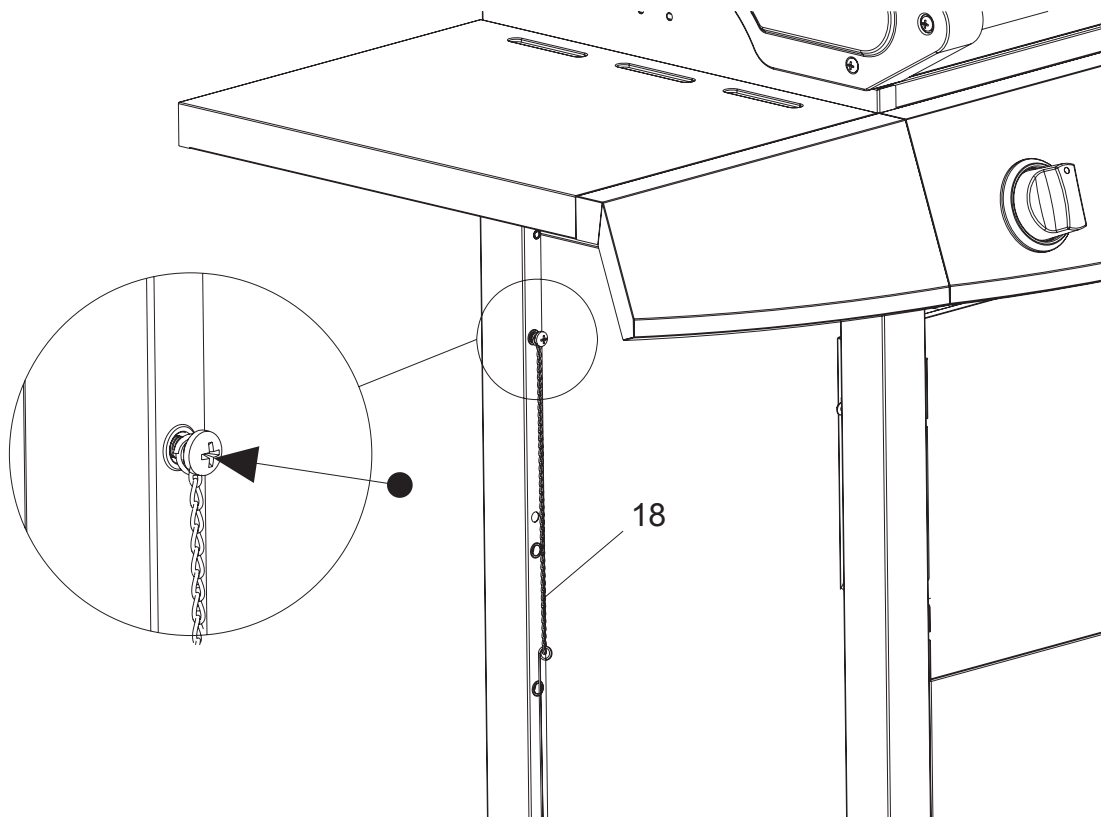
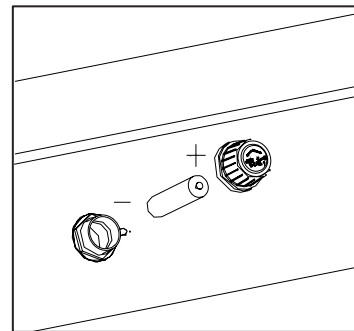

ASSEMBLY

Steg 14:

Anslut till gas

- (1) Skruva in gasinloppsmunstycket (24) på inloppet på grillen och dra åt det med en skiftnyckel.
- (2) Anslut gasslangen till gasinloppet (24) på grillen. Dra åt slangklämman väl.

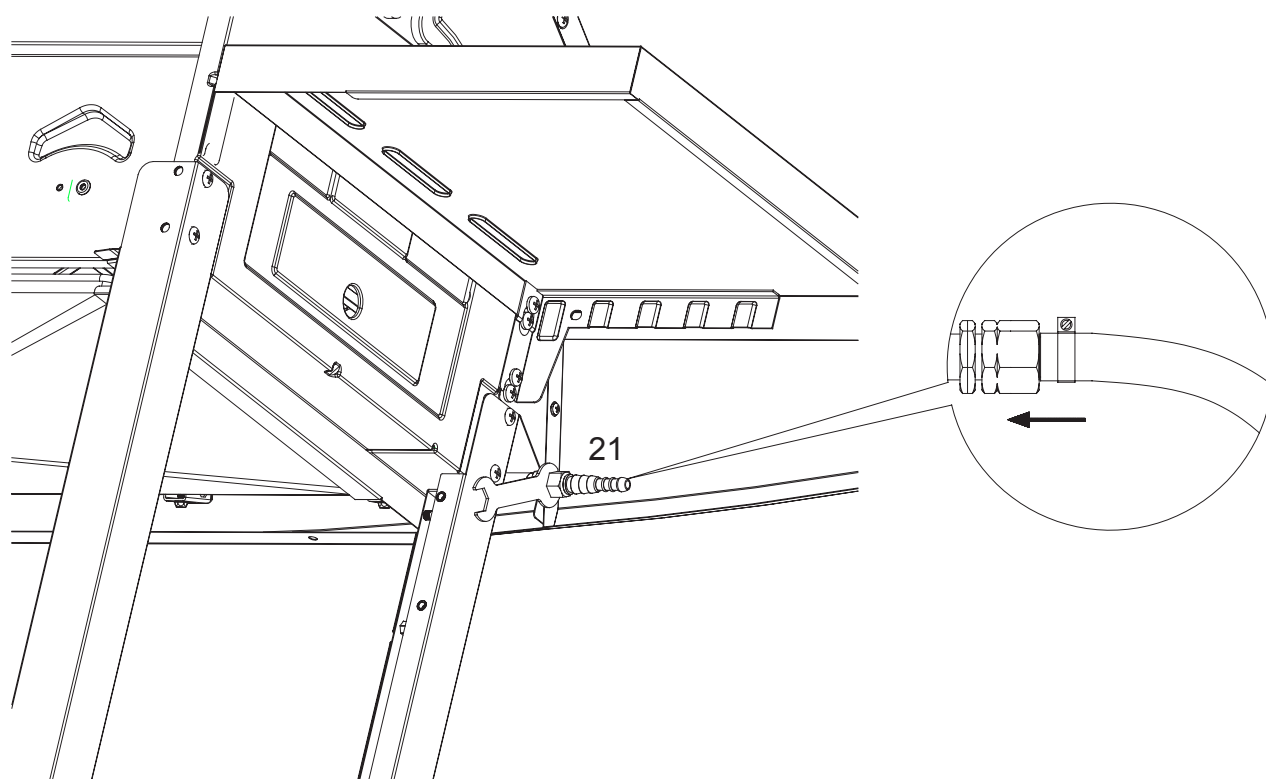

ASSEMBLY IS NOW COMPLETE.

ALL JOINTS AND CONNECTIONS MUST NOW BE LEAK TESTED BEFORE USING THE GRILL. READ CAREFULLY CHAPTER ON LEAK TESTING.

ASSEMBLY



GAS LEAK TEST



ALL JOINTS AND CONNECTIONS MUST BE LEAK TESTED BEFORE USING THE GRILL. LEAK TEST ANNUALLY, AND WHENEVER THE GAS BOTTLE IS REMOVED OR REPLACED. ALWAYS PERFORM A LEAK TEST IN A WELL- VENTILATED AREA. NEVER USE AN OPEN FLAME TO PERFORM A GAS LEAK TEST.

- Make a mixed solution ($\frac{1}{2}$ water and $\frac{1}{2}$ liquid detergent / soap).
- Ensure that there are no naked flames, heat sources and cigarettes in the vicinity when performing a leak test.
- Check that all controls on the grill are in the "OFF" position.
- Set the regulator to the "OFF" position and connect it to the gas bottle.
- Apply the liquid to all joints and connections on the gas bottle, regulator, the entire hose and all valves on the grill.
- Open the gas tap on the regulator and carefully check for bubbles appearing anywhere the liquid has been applied.
- IF BUBBLES APPEAR, SWITCH OFF THE GAS SUPPLY AND REPAIR THE PROBLEM. PERFORM A NEW LEAK TEST. DO NOT USE THE GRILL BEFORE YOU ARE SURE THAT THERE ARE NO LEAKS.
- If there are still gas leaks after repeated attempts, contact your dealer.

CONNECTING GAS



**NEVER STORE THE GAS BOTTLE UNDER THE GRILL WHEN IN USE.
IF THE GAS BOTTLE IS BEING STORED UNDER THE GRILL WHEN NOT IN USE,
DISCONNECT THE REGULATOR.
NEVER MOVE THE GRILL WHILE IT IS IN USE, OR CONNECTED TO THE GAS BOTTLE**

HOSE

Attach the gas hose to the inlet located under the left side table. Use a screwdriver, 7 mm socket wrench or spanner to tighten the screw. Tip when connecting the hose is to add soap on the gas nipple and hose for easier attachment. You can also dip the hose in boiling water. This will expand the hose so it will be easier to attach, be quick when you do this.

Connect the gas hose to the gas rail inlet on the left hand side of the barbecue. Do not overtighten.

Do not use any sealing tape, paste or liquid on the connection.

Connect the regulator to the gas bottle according to your regulator and bottle dealer's instructions.

Gas hoses used for this product must not exceed 120 cm in length

REGULATOR

Confirm all barbecue control knobs are in the OFF position.

We recommend propane gas for use in the Nordic Region, but butane can also be used. Butane is not very suitable for low temperatures.

Fit the regulator and the hose. Follow the assembly instructions supplied with the regulator set.

GAS BOTTLE

Check the gas hose regularly for cracks, damage and decay. Never use a damaged gas hose.

Check that the movable plastic collar on the regulator is intact and that it has not been damaged by hot grill parts.

Check that the gas bottle stands on a firm, flat surface and is lower than the connector.

Use an approved gas bottle that fits the regulator supplied. Bottles of 10/11 kg or above are recommended.

GAS TYPE

I3B/P(30): G30(Butane), G31(propane) and mixture of these, LPG 28-30 mbar

LIGHTING INSTRUCTIONS

1. Always keep lid open when lighting the grill
2. Check that all controls are in the "OFF" position. Open the gas supply valve on the regulator.
3. Push and hold the ignitor button, at the same time push and turn any control knob slowly to "MAX" position. Press the ignitor button until the grill is lit. If the burner do not to light within 5 seconds, shut down the gas supply and wait 5 minutes, then, repeat the procedure.
4. When the first burner is lit, ignite the next burner. Ignite one burner at a time in the same way as step 4. Make sure one burner is lit before igniting another.
5. If the burner will not ignite after repeatedly attempts, use a match and do a manual ignition.
6. Always preheat the grill on max temperature for 10-15 minutes (lid must be closed) before placing food on the cooking grid.

MANUAL LIGHTING

If the barbecue will not light using the ignitor button, use the following procedure for manual lighting.

1. Follow step 1-2 on lighting instructions.
2. Use a match holder with a match or a fireplace lighter. Hold the flame next to the ignition hole on the left or right side of the firebox where the valve is opened.

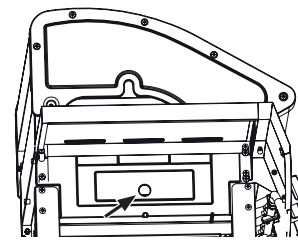

3. Turn the control knob to the MAX position and make sure the burner lights and stays lighted.
4. Ignite the remaining burners by turning the control to full power. Light one burner at a time.
5. Follow step 6.

LIGHTING INSTRUCTIONS



FLAMES SHOULD BE BLUE AND STABLE. IF THE FLAMES ARE LARGE AND YELLOW, FLARING OR 'BROKEN', CHECK THE TROUBLESHOOTING MANUAL.

NEVER DOUSE THE GRILL WITH WATER WHEN THE SURFACES ARE HOT.

TURNING OFF THE GRILL

Switch off the gas supply at the bottle.
Turn all control valves to the "OFF" position.
Wait until the barbecue is sufficiently cool
before closing its hood.

**IF THE GRILL WILL NOT LIGHT
USING NORMAL
OR MANUAL LIGHTING, REFER
TO THE TIPS SECTION IN THE
TROUBLESHOOTING MANUAL,
OR CONTACT YOUR DEALER.**

BEFORE USING THE GRILL

LOCATION

- Ensure that the grill is placed at least 150cm in all directions from house walls, trees, plants and other flammable materials or liquids when in use.
- Do not place the grill under a roof or overhang.
- Ensure the grill is placed where there is plenty of ventilation.
- Do not grill below normal ground level.

FINAL CHECK

- Check that all controls knobs work normally.
- Check that the gas hose is free of cracks and damage (it should always be done before using the grill).
- Check that the gas bottle and hose do not come into contact with hot objects.

WARNING!

THIS GRILL IS NOT DESIGNED TO BE USED WITH MORE THAN 50% OF THE COOKING AREA AS A SOLID PLATE — THIS INCLUDES BAKING DISHES.

FULL COVERAGE WILL CAUSE EXCESSIVE BUILD-UP OF HEAT AND DAMAGE THE BARBECUE. THIS IS NOT COVERED BY WARRANTY.

GRILLING TIPS

A CLEAN GRILL WORKS BETTER, causes less smoke and prevents fat catching fire. Burn off the grill after use by opening the lid and burning all the burners at full power for 10 minutes. Allow the grill to cool, and then brush off ash from flame guards and grates.

BRUSH THE GRATES WITH AN OIL that can tolerate high temperatures. This prevents food from burning onto the grates.

PREHEAT THE GRILL for around 10 minutes at full power before placing food on the grates. This gives a better result, and cuts grilling time.

DO NOT GRILL FROZEN FOOD. The cold will extend grilling time and give a poorer result.

DIVIDE THE GRILL INTO HOT AND COLD ZONES. When the food is half-ready, move it to the coldzone to finish grilling. This gives a better result and cooks the food through without it being burnt.

ASSESS COOKING TIME FOR EACH PRODUCT to be grilled and put them on the grill in the order which will mean they are ready at the same time.

BRUSH THE FOOD REGULARLY WHILE GRILLING with oil or other marinade. It makes the food stays juicy for longer.

DO NOT OPEN THE LID IF NOT NECESSARY. When the lid is opened, a lot of the heat escapes.

FAT FIRE



FIRES CAUSED BY FAT DAMAGE ON THE METAL, PAINT AND ENAMEL. DAMAGE TO THE GRILL CAUSED BY FAT BURNING, IS NOT COVERED BY THE GUARANTEE AS IT IS DUE TO INCORRECT USE.

DO NOT USE WATER TO EXTINGUISH THE FIRE! CLEAN THE GRILL REGULARLY TO AVOID FAT FIRES.

PREVENT FAT FIRE

1. Keep the grill clean to prevent fires caused by fat.
2. Fill the fat tray with a fat-absorbing material, such as cat litter or absorbent sand. This will absorb fat and food oils to prevent fat fires. Aluminiumfoil can be laid in the bottom of the tray first to make cleaning easier.

IN THE EVENT OF FAT FIRE

In the event of a fat fire, shut off the gas and disconnect the regulator. Leave the lid open and wait until the fire goes out.

LACK OF MAINTENANCE CAN CAUSE FAT DEPOSITS TO CATCH FIRE, CAUSING A FAT FIRE.

MAINTENANCE AND CLEANING

MAINTENANCE

- ✓ Check that the burners are burning correctly regularly.
- ✓ Remove the grill grate and flame guards.
- ✓ Light the grill normally.
- ✓ Turn the controls from low to high, check there is a difference in flame strength and that the flames are blue, not orange. If the burners act abnormally, refer to the troubleshooting chapter.
- ✓ Remove any fat or deposits from previous use with a grill brush.

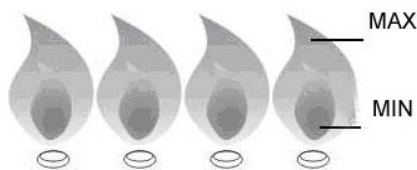

INSECTS AND VERMIN

After long-term storage, insects and other vermin can be found in the grill. If you experience problems with lighting or irregular flames, it can be due to unwanted guests blocking the gas supply. In such instances, dismantle and clean the burners. Replace the burners when they are dry.

Check that the gas hose is not damaged by mice or rats.

CLEANING

- Use clean water only. A mild washing up liquid can be added for general cleaning. Do not use flammable cleaning agents.
- To clean the grates, burn the grill for around 10 minutes after use with the lid open, and brush the grates with a grill brush. When cleaning with water, use normal washing up liquid. Do not use scouring products. Do not wash the grates in washing up liquid, it damage the enamel. Dry the grates well after cleaning and leave to soak in food oil.
- To prevent attracting vermin and odours, clean the fat tray regularly.
- Store the grill in a dry place or under a cover when not in use.
- Polish with car wax once a year to avoid rust on external parts. If living within 5 km of the sea, we recommend storing the grill indoors, as salt in the air can reduce its lifetime.
- Spread cat litter or the like in the bottom of the fat tray to absorb the fat dripping down and prevent fat fires. It also makes cleaning the tray easier.
- Rust can naturally occur on cast iron and steel parts, and will not affect the grill in the short term. Superficial rust can be washed/polished off.
- Keep the grill free of fat and grease to maintain performance.
- The fat cup should be emptied regularly to avoid it running over.
- When using a grill cover, the grill must be clean and dry and sufficient ventilation must be ensured. If not, moisture will accumulate under the cover causing rust damage.

TROUBLESHOOTING

PROBLEM	POSSIBLE CAUSE	SOLUTION
BURNER WILL NOT LIGHT WHEN USING THE IGNITION KNOB	Empty gas bottle	Replace gas bottle
	Damaged regulator	Check/replace the regulator
	Burner is blocked	Clean the burner
	Gas supply is blocked	Clean gas ventury or hose
	Electrode is broken or dirty	Clean the electrode
	Ignition knob is broken	Contact your dealer
	Windy conditions	Place the grill in a less exposed position.
	Ignition wire is damaged or fitted incorrectly	Make sure wire is mounted correctly
BURNERS WILL NOT LIGHT WHEN LIGHTING MANUALLY	Empty gas bottle	Replace gas bottle
	Irregular gas supply	Check/replace the regulator
	The burner is blocked	Clean the burner
	Gas supply or hose is blocked	Clean gas ventury or hose
LOW FLAME OR BACKFIRE	Gas bottle is too small	10/11 kg or larger bottle is recommended
	Burner is blocked	Clean the burner
	Gas supply or hose is blocked	Clean gas ventury or hose
	Windy conditions	Place the grill in a less exposed position
TROUBLE TURNING THE KNOBS	Gas valve jammed	Replace gas valve. WARNING! Knobs should be pressed in and turned
HEAVY SMOKE	Fatty foods on the grill	Trim away excess fat from meat. Clean the fat tray.
BEEPING SOUND WHEN THE GAS IS BURNING	Twisted flex hose	Straighten out the flexible hose. If the hose is bent, the barbecue can make a beeping sound.

This product is covered by a warranty in accordance with consumer legislation. It has undergone strict quality controls and testing at the factory.

If there are any parts missing or the product has been damaged, please contact your dealer or the consumer contact below for help.

Faults due to misuse, lack of maintenance or modification of the product will invalidate the warranty.

Damaged parts not due to a fault with the product will be invoiced according to our price list + carriage and administration fee.

If new parts are needed or in the event of a warranty claim, please contact your dealer or consumer contact:

Consumer contact:

Nordic Season Products AS
Kjeller Vest 3
2007 Kjeller, Norge
e-mail: support@nordicseason.no
tlf: 0047 924 78 600 (10-14 mon-fri)
www.nordicseasonbbq.no

Always attach your receipt when making a warranty claim.
Produced in China for Nordic Season Asia Co., Ltd.

NORD C
SEAS N
B A R B E C U E